

SECTION	TITLE
1	CONTENTS
2	STRUCTURE COMPONENTS
3	SEALING
4	TOP STACK COMPLETE
5	INTERIOR TRIM
6	EXTERIOR TRIM

INCL

1991.5 UPDATE

DRAWING RELEASED		DATE
BY	REVISION	DATE
 asc Incorporated Engineering Department Engineering Center Northridge, California 91329		1-75-01 1-75-02 1-75-03 1-75-04 1-75-05 1-75-06 1-75-07 1-75-08 1-75-09 1-75-10 1-75-11 1-75-12 1-75-13 1-75-14 1-75-15 1-75-16 1-75-17 1-75-18 1-75-19 1-75-20 1-75-21 1-75-22 1-75-23 1-75-24 1-75-25 1-75-26 1-75-27 1-75-28 1-75-29 1-75-30 1-75-31 1-75-32 1-75-33 1-75-34 1-75-35 1-75-36 1-75-37 1-75-38 1-75-39 1-75-40 1-75-41 1-75-42 1-75-43 1-75-44 1-75-45 1-75-46 1-75-47 1-75-48 1-75-49 1-75-50 1-75-51 1-75-52 1-75-53 1-75-54 1-75-55 1-75-56 1-75-57 1-75-58 1-75-59 1-75-60 1-75-61 1-75-62 1-75-63 1-75-64 1-75-65 1-75-66 1-75-67 1-75-68 1-75-69 1-75-70 1-75-71 1-75-72 1-75-73 1-75-74 1-75-75 1-75-76 1-75-77 1-75-78 1-75-79 1-75-80 1-75-81 1-75-82 1-75-83 1-75-84 1-75-85 1-75-86 1-75-87 1-75-88 1-75-89 1-75-90 1-75-91 1-75-92 1-75-93 1-75-94 1-75-95 1-75-96 1-75-97 1-75-98 1-75-99 1-75-100
1991.5 "F" BODY CONVERTIBLE CONTENTS		1-75-01 1-75-02 1-75-03 1-75-04 1-75-05 1-75-06 1-75-07 1-75-08 1-75-09 1-75-10 1-75-11 1-75-12 1-75-13 1-75-14 1-75-15 1-75-16 1-75-17 1-75-18 1-75-19 1-75-20 1-75-21 1-75-22 1-75-23 1-75-24 1-75-25 1-75-26 1-75-27 1-75-28 1-75-29 1-75-30 1-75-31 1-75-32 1-75-33 1-75-34 1-75-35 1-75-36 1-75-37 1-75-38 1-75-39 1-75-40 1-75-41 1-75-42 1-75-43 1-75-44 1-75-45 1-75-46 1-75-47 1-75-48 1-75-49 1-75-50 1-75-51 1-75-52 1-75-53 1-75-54 1-75-55 1-75-56 1-75-57 1-75-58 1-75-59 1-75-60 1-75-61 1-75-62 1-75-63 1-75-64 1-75-65 1-75-66 1-75-67 1-75-68 1-75-69 1-75-70 1-75-71 1-75-72 1-75-73 1-75-74 1-75-75 1-75-76 1-75-77 1-75-78 1-75-79 1-75-80 1-75-81 1-75-82 1-75-83 1-75-84 1-75-85 1-75-86 1-75-87 1-75-88 1-75-89 1-75-90 1-75-91 1-75-92 1-75-93 1-75-94 1-75-95 1-75-96 1-75-97 1-75-98 1-75-99 1-75-100
A-27X0-4960-AXXX		SHEET 1

SHEET	TITLE
2	CONTENTS - STRUCTURE/WELDING
2A	ROCKER OUTER REINFORCEMENT
2B	ROCKER INNER REINFORCEMENT
2C	AUXILIARY "B" PILLAR REINFORCEMENT- RETRACTOR MOUNTING PLATE
2D	SUPPORT BRACKETS AND GUSSET - D/RING ASSEMBLY
2E	TROUGH ASSEMBLY - QUARTER SIDE AND REAR
2F	TROUGH CORNER AND AUXILIARY "B" PILLAR BRACE
2G	DECK LID HINGE AND MOUNTING BRACKET

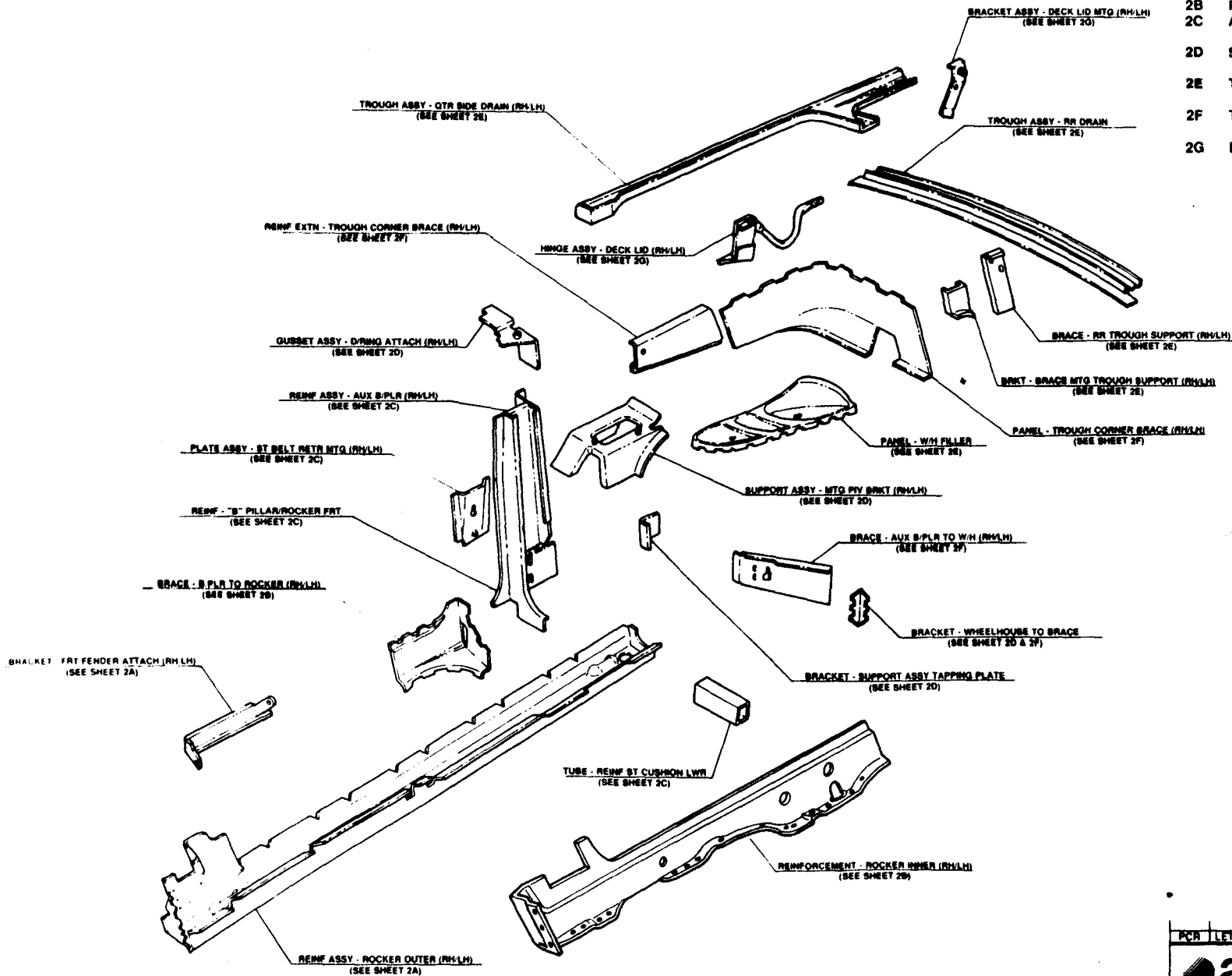

DRAWING RELEASED		1-25-91	MB	12
PCB	LET	REVISIONS	DATE	DR
		ASC Incorporated Graphics Department Engineering Center Southgate, Michigan 48196		
TITLE 1991.5 "F" BODY CONVERTIBLE CONTENTS - STRUCTURE/WELDING		DRAWN BY MONTGOMERY CHECKED BY C. WEBER APPROVED BY S. DENHORE		
PART NUMBER A-27X0-4960-AXXX		SHEET 2		

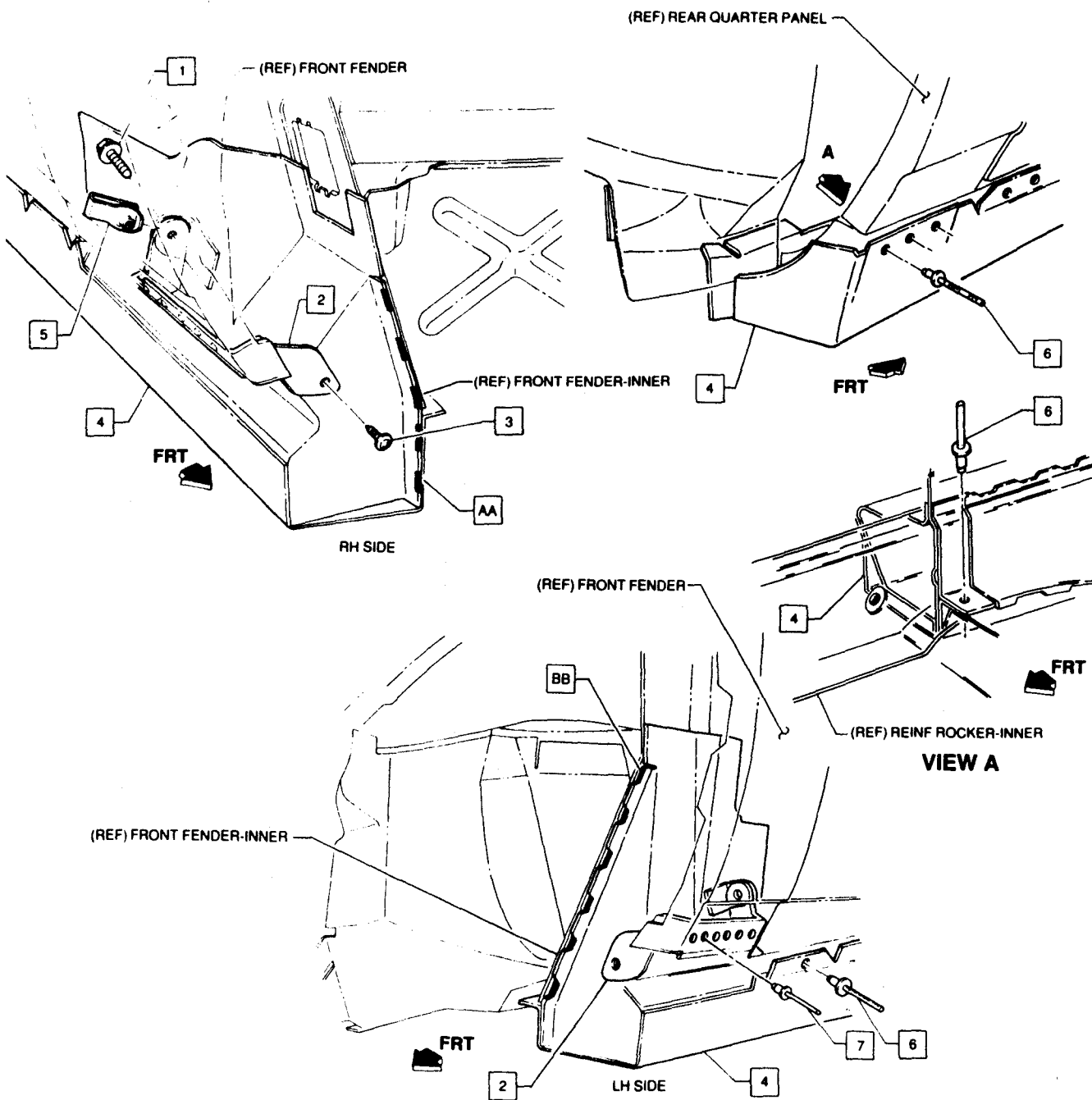

Ref	ASC Part No	Description	GM
1	K - 0080 - 1922 - XWYX	SCR & WSHR ASSY (M6 X 1.0 x 20.0)	11992041
2	W - 27X0 - 0982	BRKT - FRONT FENDER ATTACHING (RH)	12994773
		(LM)	12994777
3	X - 0080 - 0173 - XW8X	SCREW (8 - 18 x .50)	20904198
4	A - 27X0 - 3642	REINF ASSY - ROCKER OUTER (RH)	12999448
		(LM)	12999427
5	X - 0080 - 1329 - XZTX	NUT - U TYPE	11969719
6	X - 0080 - 3290 - XZTX	RIVET (.763 x .825)	
7	K - 0080 - 0190 - XXXX	RIVET (1/8 x .375)	

WELD INFORMATION

SYM	TYPE	QTY	SIZE	CLASS	LOCATION
AA	MIG	5	1.0mm	B	4 TO (REF) FRONT FENDER - INNER
BB	MIG	6	1.0mm	B	4 TO (REF) FRONT FENDER - INNER

WELD CLASSIFICATION
 A - FINISH
 B - STRUCTURAL
 NOTE: ALL COMPONENTS MUST FIT NET TO 2 MM MAX. GAP TO SHEET METAL AT ALL MIG WELD LOCATIONS

SERVICE ONLY

W - 27X0 - 9622/23	PKG - FRT FOR MODIFICATION (REV.4)	1299740/41
CONSISTS OF:		
W - 27X0 - 3641	INSTR SHEET - FRT FOR MODIFICATION	
2		

DRAWING RELEASED

LET REVISIONS DATE DR CK TAPP

asc ASC Incorporated
 11500 1/2 Department
 Engineering 1, 2nd
 20000 1/2 Highway 60100

1991.5 "F" BODY CONVERTIBLE
 ROCKER OUTER REINFORCEMENT

DESIGNED BY C. WEBER
 CHECKED BY S. BERNDSON

A-27X0-4960-AXXX SHEET 2A

Ref	ASC Part No	Description	GM
1	W - 27X0 - 3500	BRACE - B/PLR TO ROCKER (RH)	12504774
	W - 27X0 - 3081	(LM)	12504775
2	W - 27X0 - 7170	REINF - ROCKER INNER (RH)	12507840
	W - 27X0 - 7177	(LM)	12300220
3	X - 0000 - 3200 - XZTX	RIVET (.236 x .825)	

WELD INFORMATION

SYM	TYPE	QTY	SIZE	CLASS	LOCATION
AA	SPOT	16	---	B	2 TO (REF) ROCKER INNER
BB	MIG	3	1.5mm	B	1 TO (REF) ROCKER INNER
CC	MIG	2	1.5mm	B	1 TO 2
DD	MIG	2	1.8mm	B	1 TO (REF) FLOOR PAN
EE	MIG	2	1.8mm	B	1 TO (REF) REINF - B/PLR RKR FRT

WELD CLASSIFICATION
A - FMVSB
B - STRUCTURAL
NOTE: ALL COMPONENTS MUST FIT NET TO 2MM MAX GAP TO SHEET METAL AT ALL MIG WELD LOCATIONS

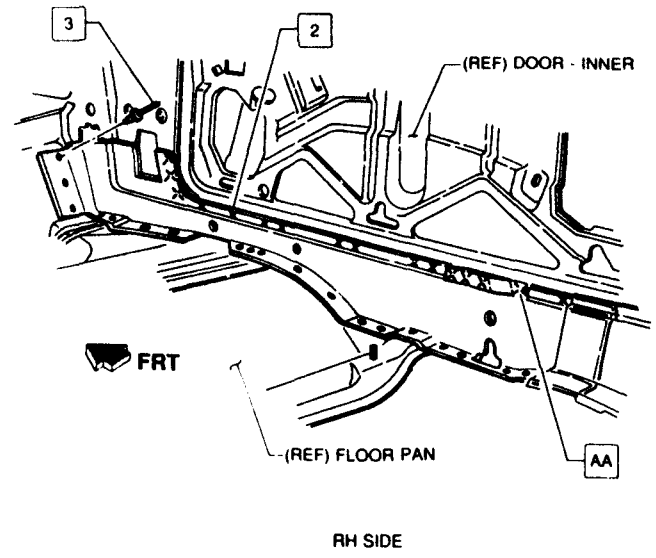
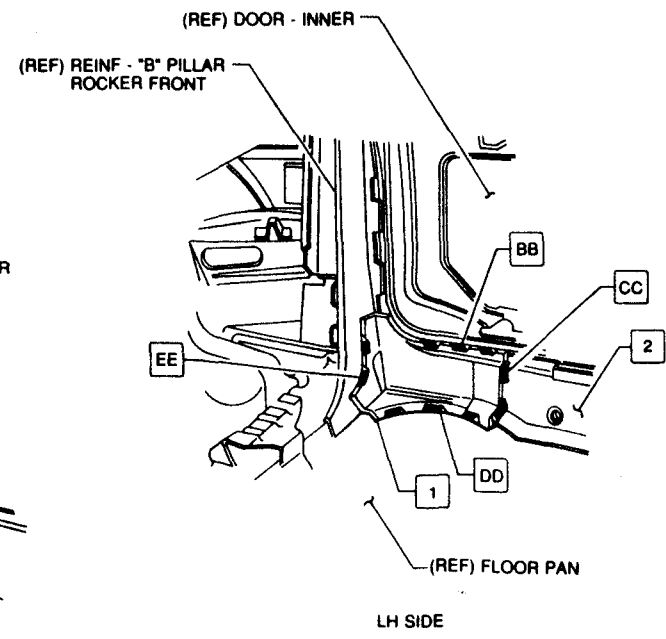
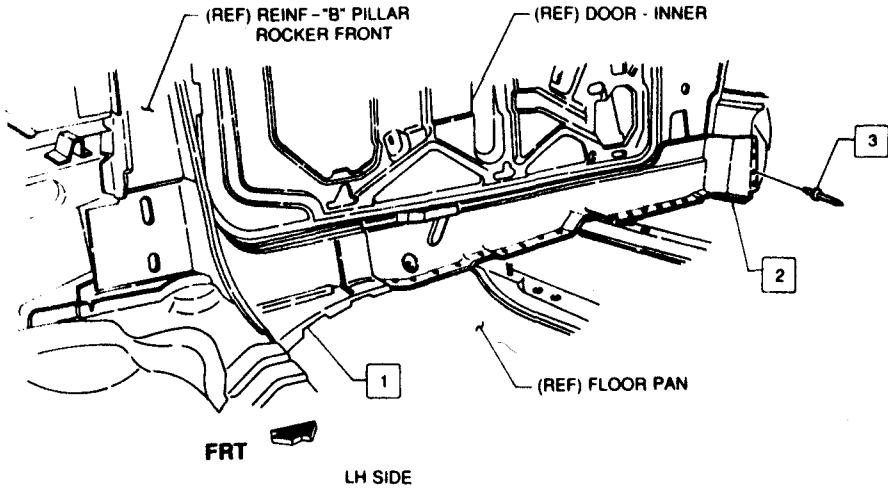

PCB	LET	DRAWING RELEASED	1-25-91	MR	2000
		REVISIONS	DATE	DR	CHK / APP
		Asc Incorporated Graphical Department Engineering Center Southgate Michigan 48196	COMPLETION DATE 1-30-91		
TITLE 1991.5 "F" BODY CONVERTIBLE ROCKER INNER REINFORCEMENT					ILLUSTRATED BY M. BOGOLAU
PART NUMBER A-27X0-4960-AXXX					TRACED REVISED BY MONTGOMERY
SHEET 2B					CHECKED BY C. WEBER
APPROVED BY S. WEBER					

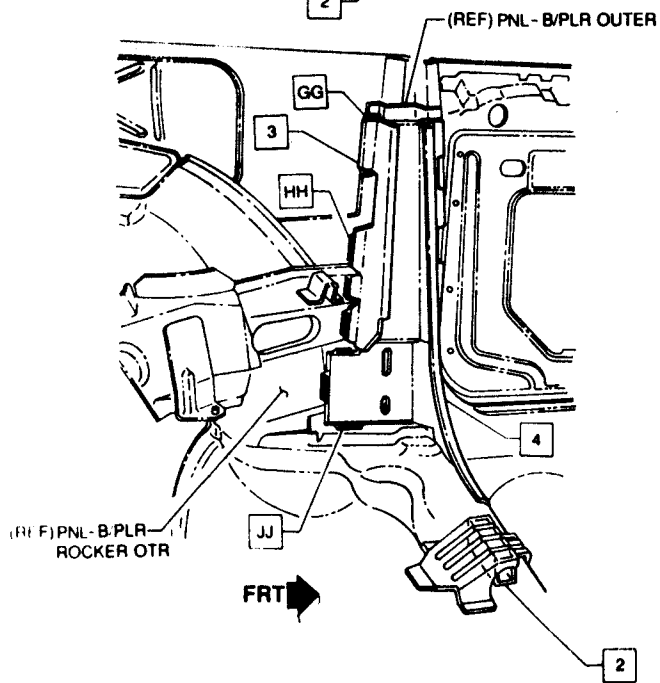
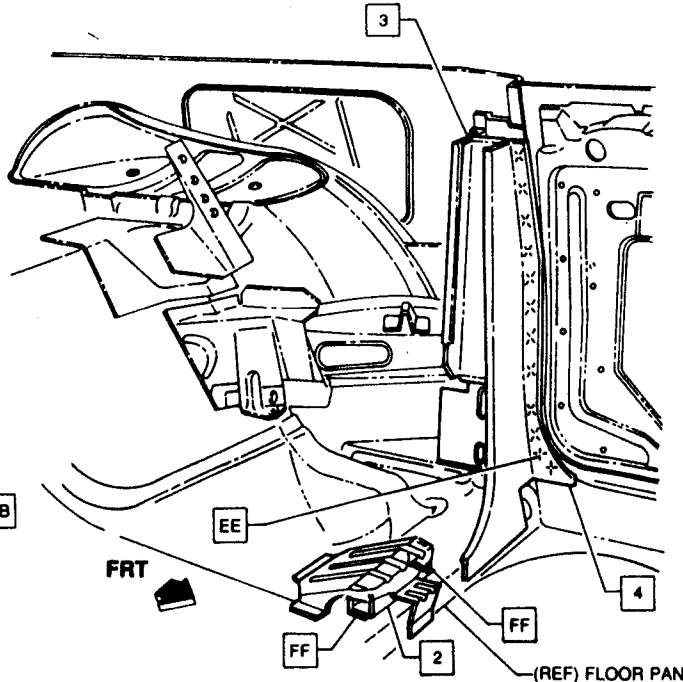
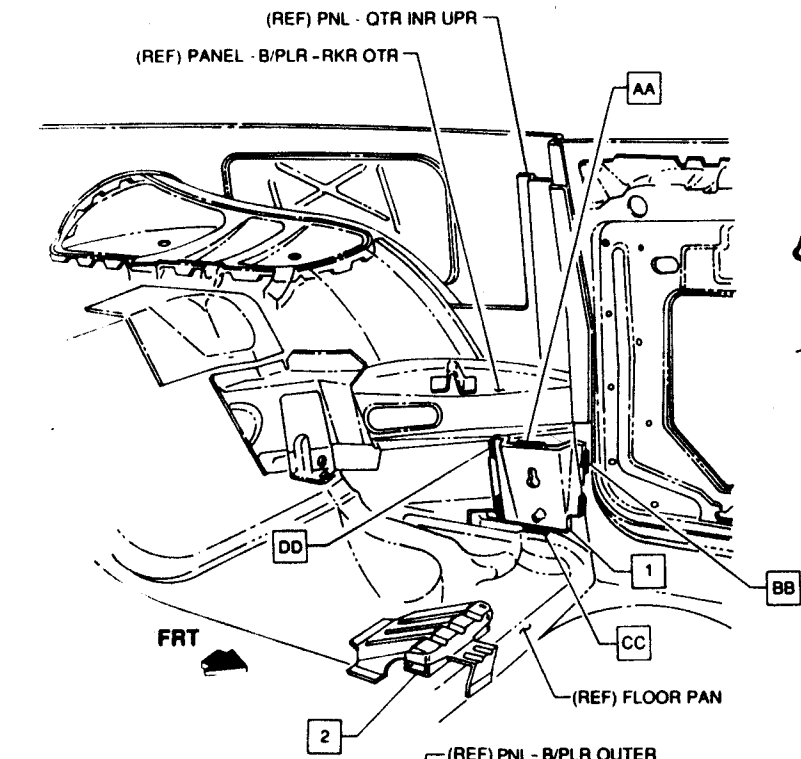

Ref	ASC Part No	Description	GM
1	W - 27X0 - 7414	PLATE ASSY - ST BELT RETR MTG (RH)	12904880
	W - 27X0 - 7415	(LM)	12904881
2	V - 27X0 - 6624	TUBE - REINF SEAT CUSHION LWR	12388188
3	T - 27X0 - 3582	REINF ASSY - AUX B/PLR (RH)	12388042
	T - 27X0 - 3583	(LM)	12388043
4	W - 27X0 - 3252	REINF - B/PLR ROCKER FRT (RH)	12908124
	W - 27X0 - 3253	(LM)	12908125

WELD INFORMATION

SYM	TYPE	QTY	SIZE	CLASS	LOCATION
AA	MG	1	1.5mm	A	1 TO (REF) PNL - B/PLR RKR OTR
BB	MG	2	1.5mm	B	1 TO (REF) PNL - QTR INR UPR
CC	MG	1	1.5mm	A	1 TO (REF) FLOOR PAN
DD	MG	2	1.5mm	B	1 TO (REF) PNL - B/PLR RKR OTR
EE	SPOT	12		B	4 TO (REF) PNL - B/PLR OTR
FF	MG	2	1.0mm	A	2 TO (REF) FLOOR PAN
GG	MG	2	1.5mm	A	2 TO (REF) PNL - B/PLR OTR
HH	MG	3	1.5mm	A	3 TO (REF) PNL - B/PLR RKR OTR
JJ	MG	2	1.5mm	B	2 TO (REF) PNL - B/PLR RKR OTR

WELD CLASSIFICATION
 A - FMVSS
 B - STRUCTURAL

NOTE: ALL COMPONENTS MUST FIT NET TO 2 MM MAX GAP TO SHEET METAL AT ALL MG WELD LOCATIONS

DRAWING RELEASED 1-28-01

PCB	LET	REVISED	DATE	BY	CHK	APP
-----	-----	---------	------	----	-----	-----

asc. ASC Incorporated
 Graphics Department
 Engineering Center
 Naunton, Michigan 48155

1991.5" BODY CONVERTIBLE
 AUXILIARY "B" PILLAR REINFORCEMENT -
 RETRACTOR MOUNTING PLATE

A-27X0-4960-AXXX SHEET 2C

Ref	ASC Part No	Description	GM
1	T - 27X0 - 2708	GUSSET - D/RING ATTACHING (RP)	12382801
	T - 27X0 - 2707	(LH)	12382802
2	A - 27X0 - 7606	SUPPORT ASSY - MTO PIVOT BRKT (RD)	
	A - 27X0 - 7608	(LH)	
3	B - 27X0 - 1486	BRKT - SUPPORT ASSY TAPPING PLATE	12331731
4	T - 27X0 - 2824	BRKT - WHEELHOUSE TO BRACE	12331736

WELD INFORMATION

SYM	TYPE	QTY	SIZE	CLASS	LOCATION
AA	MIG	1	1.6mm	B	2 TO (REF) PNL - WHEELHOUSE
BB	MIG	1	1.6mm	B	1 TO (REF) PNL - QTR INR UPR
CC	MIG	1	1.6mm	B	1 TO (REF) "B" P/LR
DD	MIG	2	1.6mm	B	1 TO (REF) REINF ASSY - AUX B/PLR
EE	MIG	1	2.5mm	B	3 TO 2
FF	MIG	1	2.5mm	B	3 TO (REF) REINF ASSY - AUX B/PLR
GG	MIG	2	1.5mm	B	2 TO (REF) PANEL - WHEELHOUSE
HH	MIG	2	1.5mm	B	4 TO 2
JJ	MIG	2	1.6mm	B	4 TO (REF) PANEL - WHEELHOUSE

WELD CLASSIFICATION

A - FINISH
B - STRUCTURAL

NOTE: ALL COMPONENTS MUST FIT NET TO 2 MM MAX GAP TO SHEET METAL AT ALL MIG WELD LOCATIONS

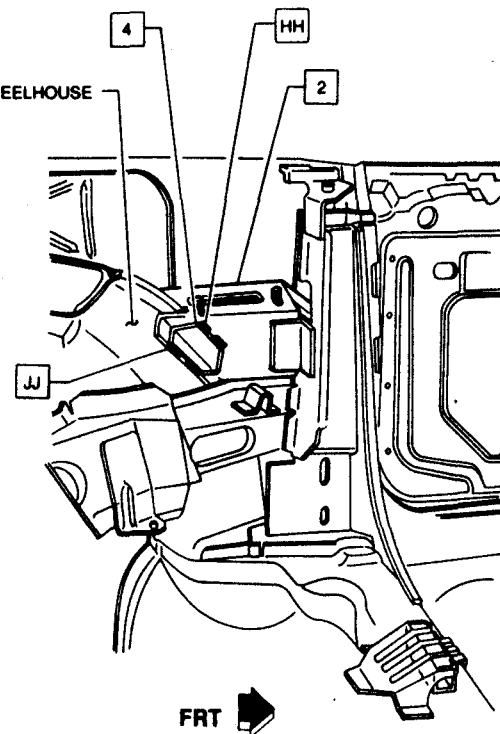
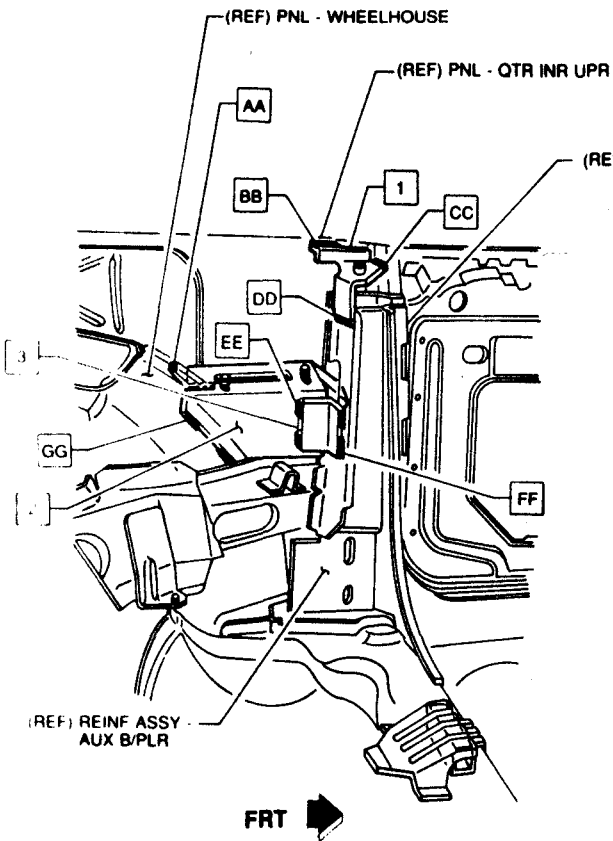

PCR	LET	REVISIONS	DATE	DR	CK	APP
		ASC Corporation Design & Engineering Northgate Manufacturing				1-30-01 1-30-01 B WHEELS
1991.5 "F" BODY CONVERTIBLE SUPPORT BRACKETS AND GUSSET - D/RING ASSEMBLY						AUTHORIZED BY MONTGOMERY C. WOODR APPROVED BY S. SCHMIDT
A-27X0-4960-AXXX						SHEET 2D

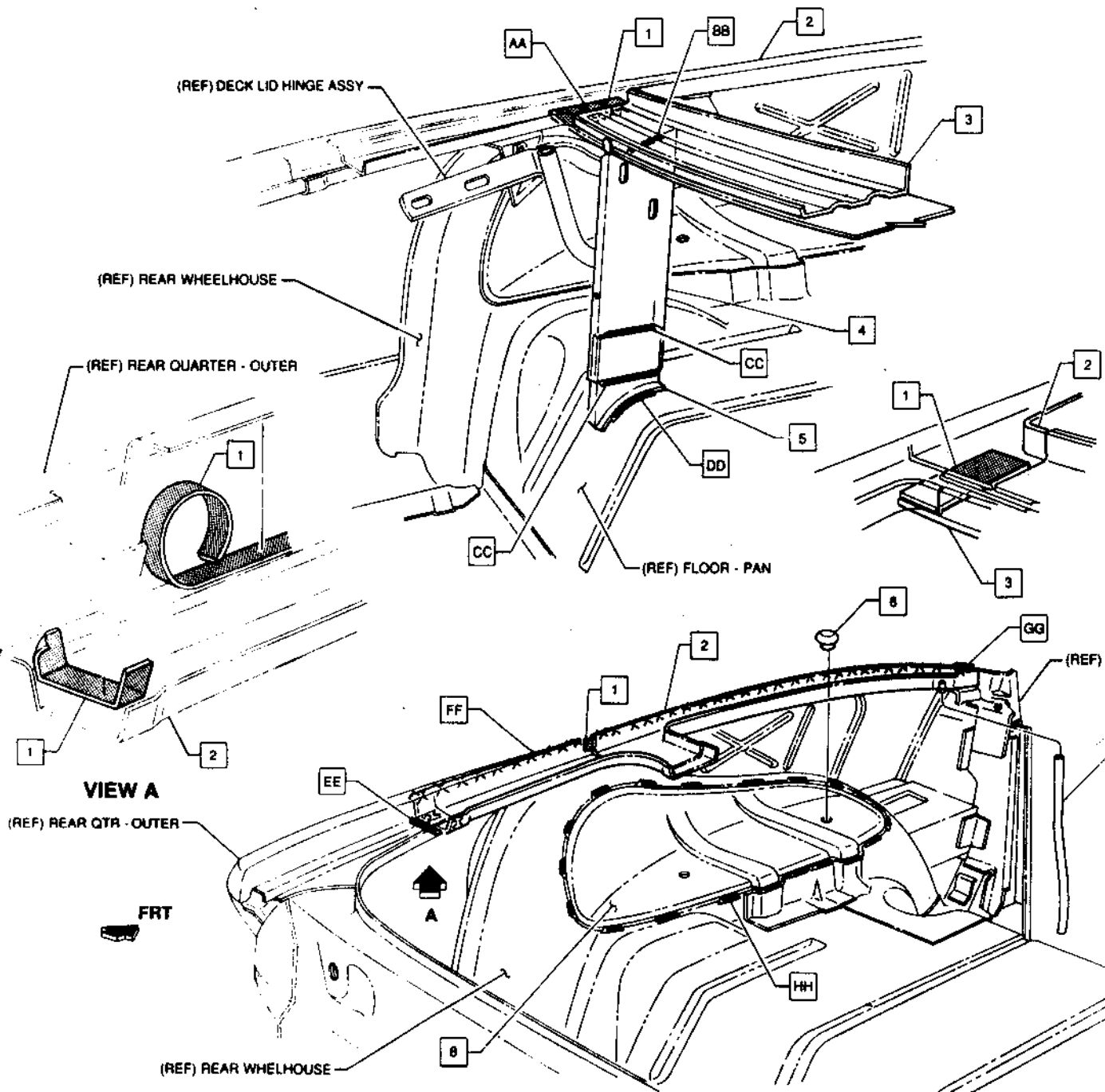

Ref	ASC Part No	Description	GM
1	X - 0080 - 0182 - AXXX	TAPE - WELD THRU	0801280
2	W - 2730 - 3152	TROUGH ASSY - QTR SIDE DRAIN (RH)	12804784
	W - 2730 - 3153	(LH)	12804786
3	B - 2730 - 3282	TROUGH ASSY - REAR DRAIN	12331713
4	T - 2730 - 8528	BRACE - REAR TROUGH SUPPORT (RH)	12304881
	T - 2730 - 8528	(LH)	12304883
5	U - 2730 - 2996	BRKT - BRACE MTO TROUGH SUPT (RH)	12304885
	U - 2730 - 2997	(LH)	12304886
6	X - 0080 - 1467 - XXXX	PLUG - RECESSED BUTTON HEAD	
7	A - 2730 - 3487	MOBE - DRAIN	12308848
8	T - 2730 - 7269	PANEL - WHEELHOUSE FILLER (RH)	12308849
	T - 2730 - 7267	(LH)	12308851

WELD INFORMATION

SYM	TYPE	QTY	SIZE	CLASS	LOCATION
AA	SPOT	8	—	B	2 TO 3
BB	MIG	1	2.0mm	B	3 TO 4
CC	MIG	2	2.0mm	B	4 TO 5
DD	MIG	1	2.0mm	B	8 TO (REF) FLOOR - PAN
EE	MIG	1	2.0mm	B	2 TO (REF) REAR QTR - QTR
FF	SPOT	22	—	B	2 TO (REF) REAR QTR - QTR
GG	MIG	1	1.0mm	B	2 TO (REF) "B" PILLAR
HH	MIG	1	1.6mm	B	8 TO (REF) REAR WHEELHOUSE

WELD CLASSIFICATION

- A - PHYS
- B - STRUCTURAL

NOTE: ALL COMPONENTS MUST FIT NET TO 2 MM MAX GAP TO SHEET METAL AT ALL MIG WELD LOCATIONS

DRAWING RELEASED

PCN (REV) DATE FOR CKT APP

asc. ASC Incorporated
 Design Department
 Engineering Center
 Southgate, Michigan 48196

1-08-01
 1991.5 "F" BODY CONVERTIBLE
 TROUGH ASSEMBLY - QUARTER SIDE AND REAR

BY: T. MICHAKIS
 C. WASSER
 S. GIBSON

A-27X0-4960-AXXX SHEET 2E

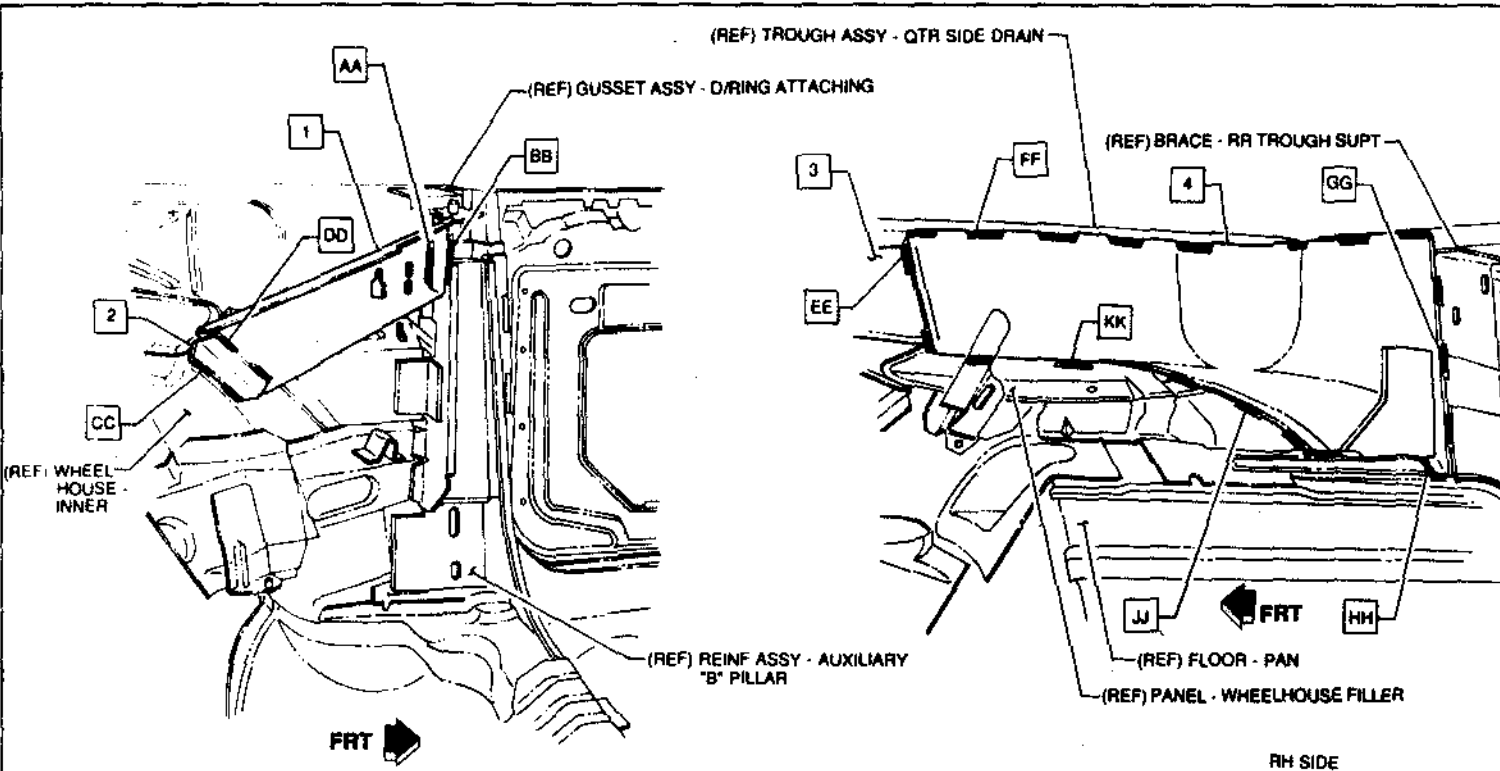

Ref	ASC Part No	Description	GM
1	T-2728-2452	BRACE - AUX B/PLA TO WH (RH)	12331724
2	T-2728-2452	(LHD)	12331725
3	T-2728-2554	BRKT - WHEELHOUSE TO BRACE	12331726
3	T-2728-2554	REINF ELTH - TROUGH CORNER BR (RH)	12331718
	T-2728-2554	(LHD)	12331719
4	T-2728-3174	PHL - TROUGH CORNER BRACE (RH)	12331720
	W-2728-3174	(LHD)	12331721

WELD INFORMATION

SYM	TYPE	QTY	SIZE	CLASS	LOCATION
AA	MIG	1	2.0mm	B	1 TO (REF) GUSSET ASSY - O/RING ATTACHING
BB	MIG	1	2.0mm	B	1 TO (REF) REINF ASSY - AUX B/PLA
CC	MIG	2	1.6mm	B	2 TO (REF) WHEELHOUSE - INNER
DD	MIG	2	1.6mm	B	2 TO 1
EE	MIG	2	1.6mm	B	4 TO 3
FF	MIG	2	1.6mm	B	4 TO (REF) TROUGH ASSY - QTR SIDE DRAIN
GG	MIG	2	1.6mm	B	4 TO (REF) BRACE - RR TROUGH SUPT
HH	MIG	2	1.6mm	B	4 TO (REF) FLOOR PAN
JJ	MIG	2	1.6mm	B	4 TO (REF) FLOOR PAN
KK	MIG	3	1.6mm	B	4 TO (REF) PHL - WH FILLER
LL	MIG	2	1.6mm	B	4 TO (REF) TROUGH ASSY - QTR SIDE DRAIN
MM	MIG	2	1.6mm	B	3 TO (REF) TROUGH ASSY - QTR SIDE DRAIN
NN	MIG	4	1.6mm	B	4 TO (REF) PHL - WH FILLER
PP	MIG	2	1.6mm	B	4 TO (REF) FLOOR PAN

WELD CLASSIFICATION
 A - PERVIS
 B - STRUCTURAL
 NOTE: ALL COMPONENTS MUST FIT NEAT TO 2 MM MAX GAP TO BRIST METAL AT ALL MIG WELD LOCATIONS

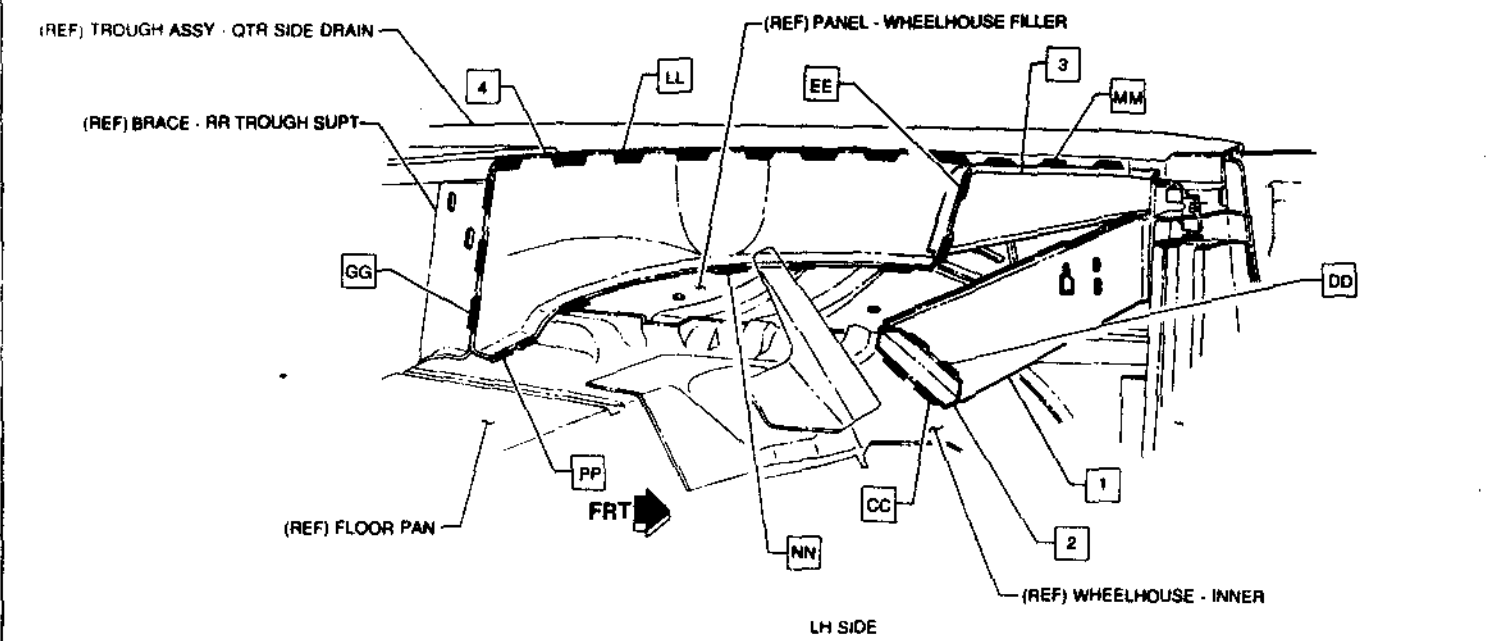

DRAWING RELEASED
 1-30-91
 ASC International
 1991.5 "F" BODY CONVERTIBLE
 TROUGH CORNER AND AUXILIARY "B" PILLAR BRACE
 A-27X0-4960-1 VVVV

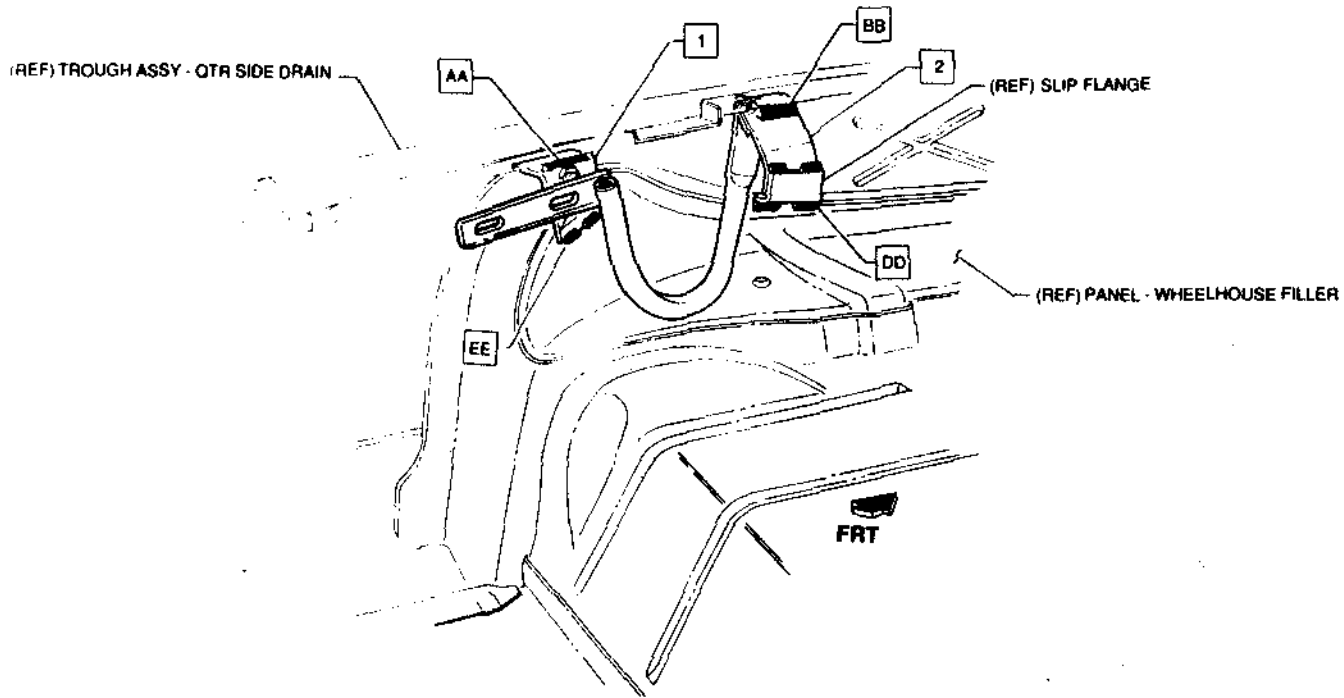

Ref	ASC Part No	Description	GM
1	B - 2730 - 0624	BRACKET ASSY - DECK LID MTO (RH)	12891731
2	B - 2730 - 0625	FLG	12891738
3	A - 2730 - 0626	WHEELHOUSE ASSY - DECK LID (RH)	
4	A - 2730 - 0627	FLG	

WELD INFORMATION

SYM	TYPE	QTY	SIZE	CLASS	LOCATION
AA	MIG	1	1.5mm	B	1 TO (REF) TROUGH ASSY - QTR SIDE DRAIN
BB	MIG	1	1.5mm	B	2 TO (REF) TROUGH ASSY - QTR SIDE DRAIN
CC	MIG	2	1.5mm	B	2 TO (REF) SLIP FLANGE
DD	MIG	2	1.5mm	B	(WELD SLIP FLG TO (REF) PNL - WH FLLR
EE	MIG	1	1.5mm	B	1 TO (REF) PNL - WH FLLR
FF	MIG	1	1.5mm	B	1 TO (REF) TROUGH ASSY - QTR SIDE DRAIN
GG	MIG	1	2.5mm	B	1 TO (REF) TROUGH ASSY - QTR SIDE DRAIN
HH	MIG	2	2.5mm	B	1 TO (REF) WHEELHOUSE INNER
JJ	MIG	1	1.5mm	B	(REF) WH - FLG TO (REF) PNL - WH FLLR
KK	MIG	1	1.5mm	B	2 TO (REF) WH - FLANGE

WELD CLASSIFICATION
 A - FIVE/8
 B - STRUCTURAL

NOTE: ALL COMPONENTS MUST FIT NET TO 2 MM MAX GAP TO SHEET METAL AT ALL MIG WELD LOCATIONS

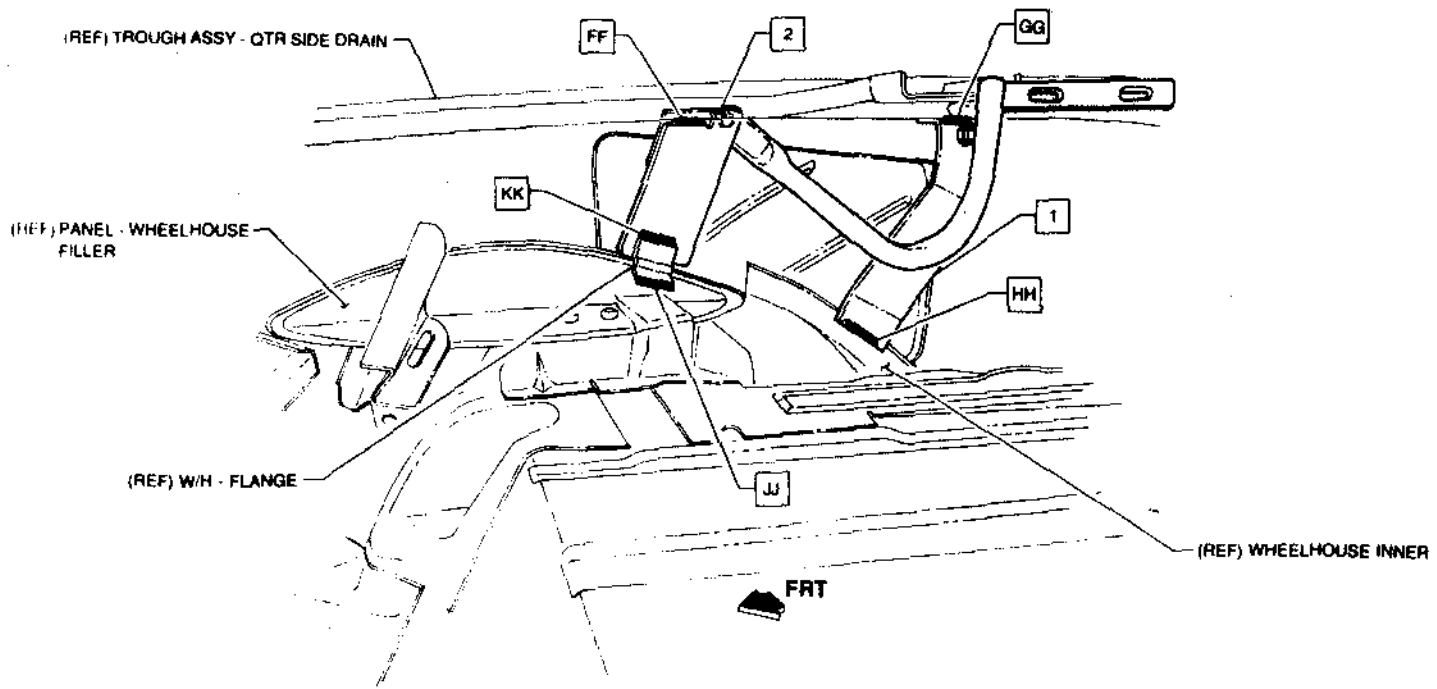

DRAWING RELEASED

1:30:41

PCN 1/1/17

REVISIONS

DATE CHG

LOC

asc.

ASC Incorporated
 Graphics Department
 Engineering Center
 Huntington, West Virginia 26030

1400-01
 11/08/14
 H. BOB LAJ
 HUNTINGTON, WEST VIRGINIA
 26030
 C. WILSON
 HUNTINGTON, WEST VIRGINIA
 26030

1991.5 "F" BODY CONVERTIBLE
 DECK LID HINGE AND MOUNTING BRACKET

A-27X0-4960-AXXX SHEET 2G

SHEET	TITLE
3	CONTENTS - SEALING
3A	SEALING - ROCKER OUTER REINFORCEMENT
3B	SEALING - ROCKER INNER REINFORCEMENT
3C	SEALING - AUXILIARY "B" PILLAR REINFORCEMENT - RETRACTOR MOUNTING PLATE
3D	SEALING - SUPPORT BRACKETS AND GUSSET - D/RING ASSEMBLY
3E	SEALING - TROUGH ASSEMBLY - QUARTER SIDE AND REAR
3F	SEALING - TROUGH CORNER AND AUXILIARY "B" PILLAR BRACE
3G	SEALING - DECK LID HINGE AND MOUNTING BRACKET

DRAWING RELEASED		DATE	BY
FOR	LET	DATE	BY
 asc. Incorporated Graphics Department Engineering Center Southgate, Michigan 48194		COMPLETION DATE 1-28-91 APPROVED BY C. WEBER DESIGNED BY J. VILLARDO CHECKED BY C. WEBER DRAWN BY S. SHAWNEE	
TITLE 1991.5 "F" BODY CONVERTIBLE CONTENTS - SEALING			
PART NUMBER A-27X0-4960-AXXX		SHEET 3	

Ref ASC Part No	Description	GM
1 2-9990-0630-AXXX	DEADENER - LIQUID	9990-170
2 2-9990-0633-BXXX	UNDERCOAT	

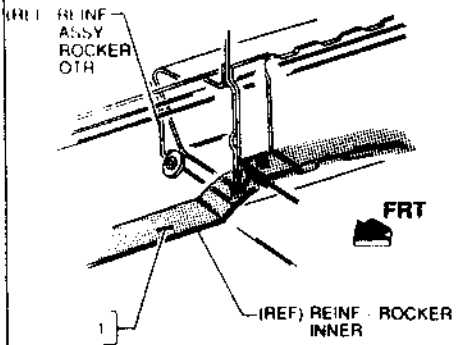
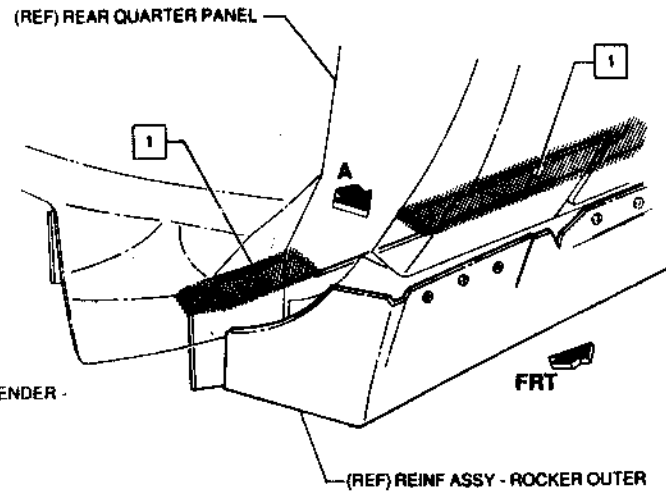
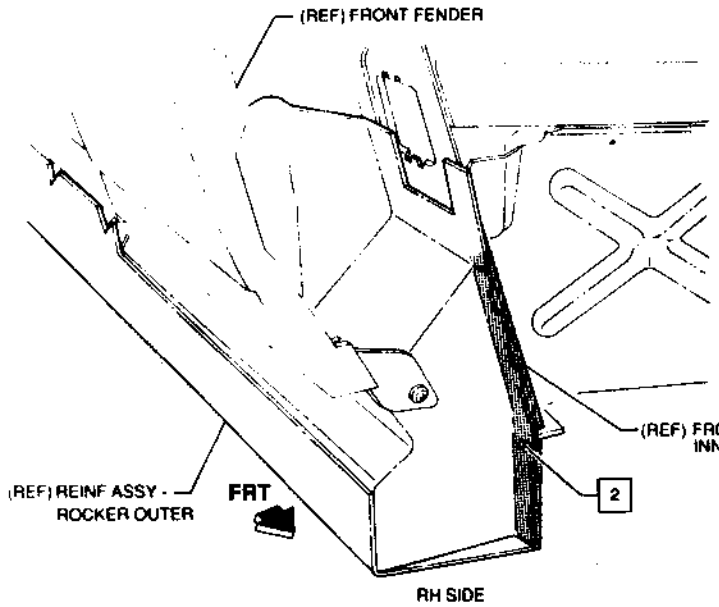

VIEW A

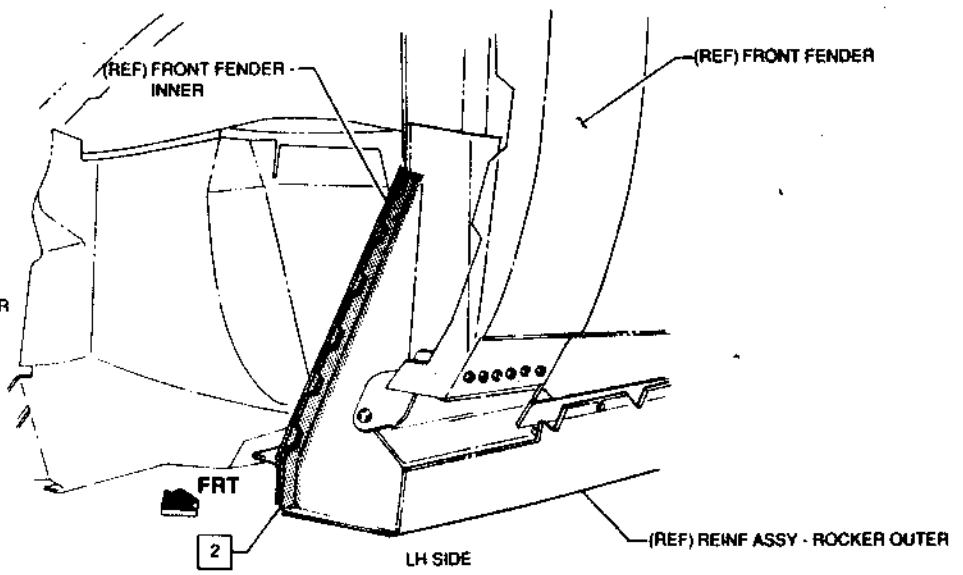

DRAWING RELEASED

asc

ASC International
 Originals Department
 Engineering Center
 Southfield, Michigan 48116

1-800-911-3822
 H. BOJLA
 T. MOORHEAD
 C. WILSON
 S. BARNETT

1991.5 "F" BODY CONVERTIBLE
 SEALING - ROCKER OUTER REINFORCEMENT

A-27X0-4960-AXXX SHEET 3A

Ref	ASC Part No	Description	GM
1	X-9990-0196-AXXX	SEALER - BRUSH ON	9991111

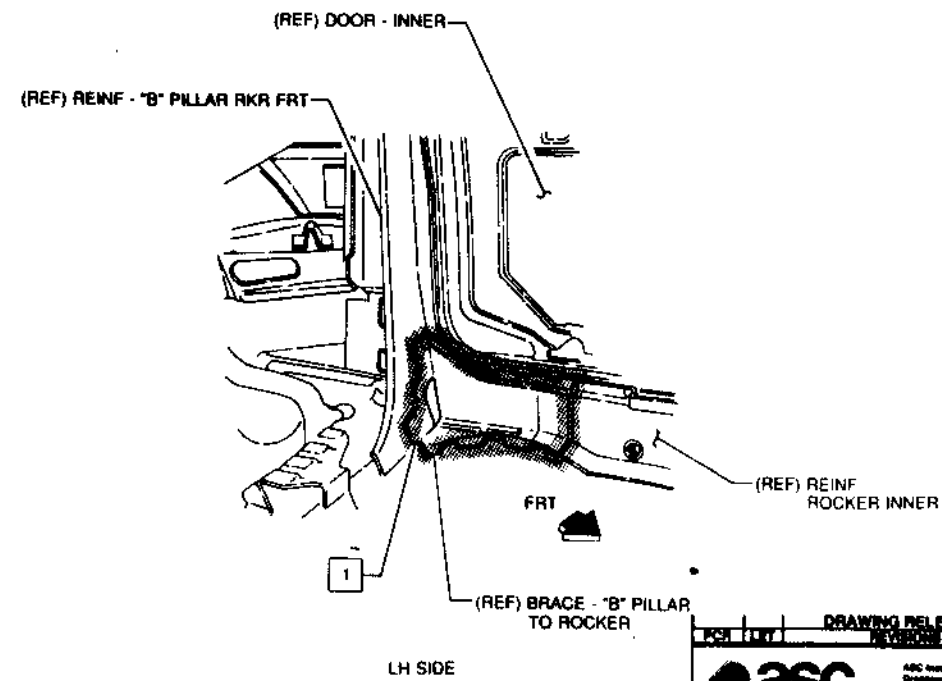
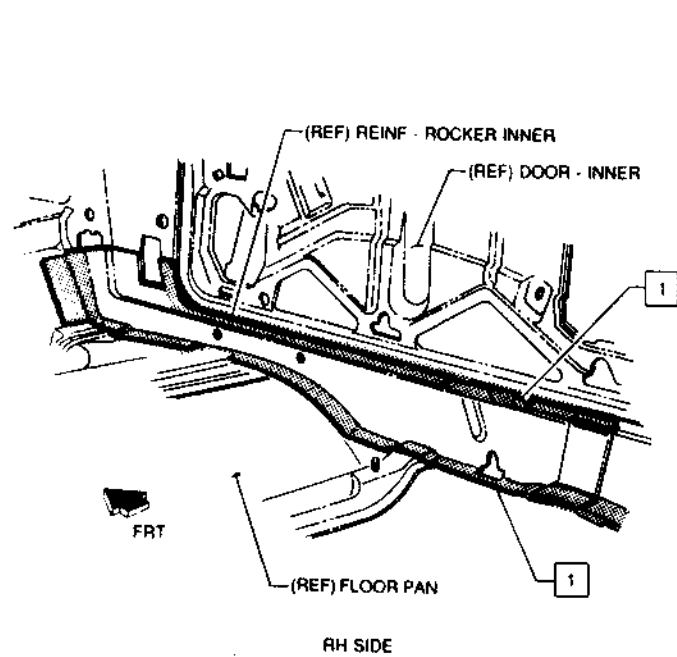
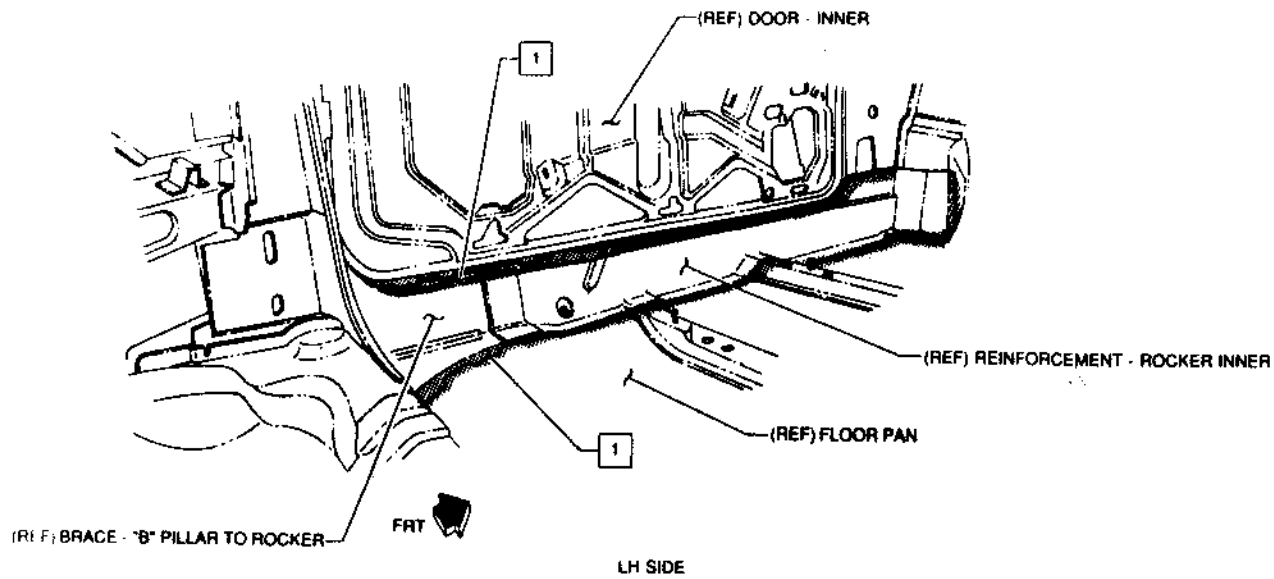

DRAWING RELEASED

asc. ASC International
 Sealing Department
 Engineering Center
 Birmingham, Michigan 48106

1991.5 "F" BODY CONVERTIBLE
 SEALING - ROCKER INNER REINFORCEMENT

A-27X0-4960-AXXX SHEET 3B

1-20-91
 E. GIBBLAY
 T. MORALES
 C. WOOD
 S. GIBBLAY

Ref	ASC Part No	Description	GM
1	X-9999-0194-AXXX	SEALER - BRUSH ON	991111

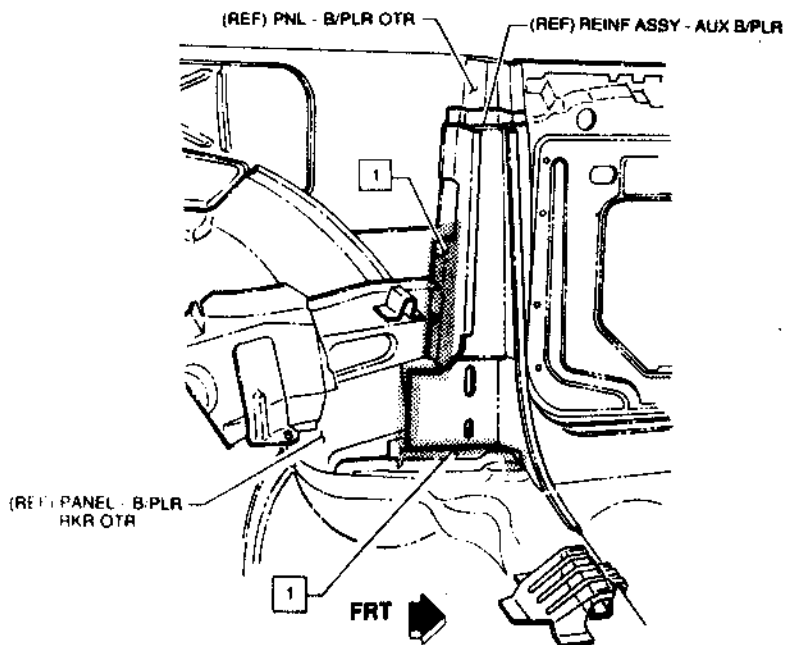
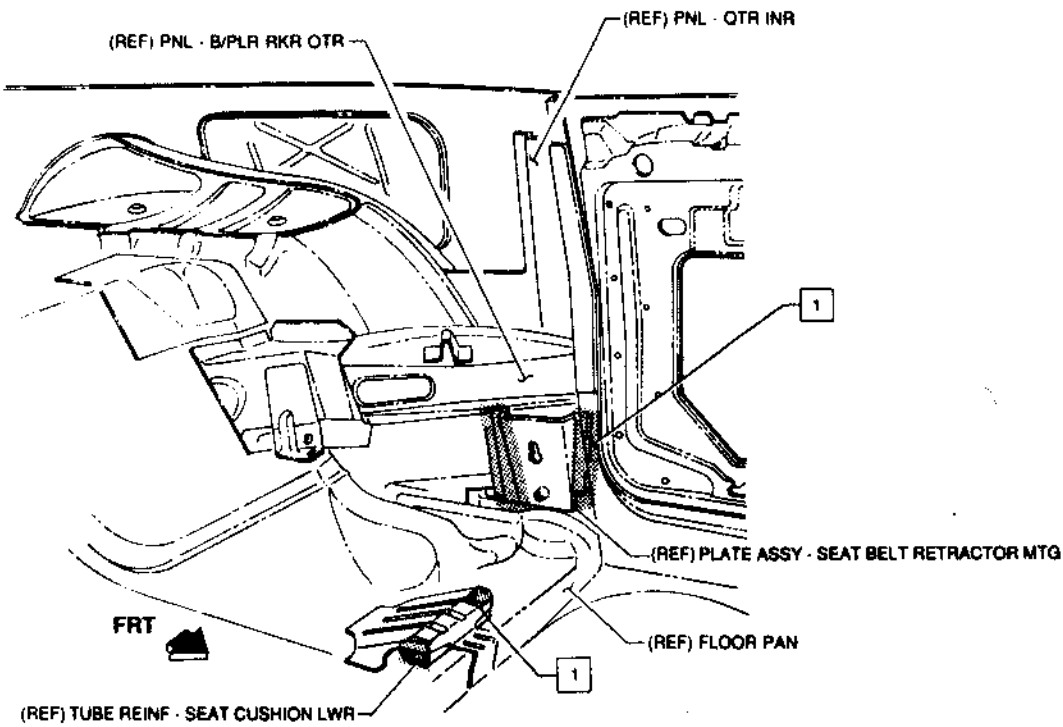

DRAWING RELEASED		DATE	BY
REVISED		DATE	BY
		ASC Incorporated Graphics Department Engineering Center Warrendale, Michigan 48090	
1991.5 "F" BODY CONVERTIBLE SEALING - AUXILIARY "B" PILLAR REINFORCEMENT - RETRACTOR MOUNTING PLATE			
A-27X0-4960-AXXX		SHEET 3C	

Ref	ASC Part No	Description	GM
1	8-2000-9124	AXXX SEALER - BRUSH ON	991111

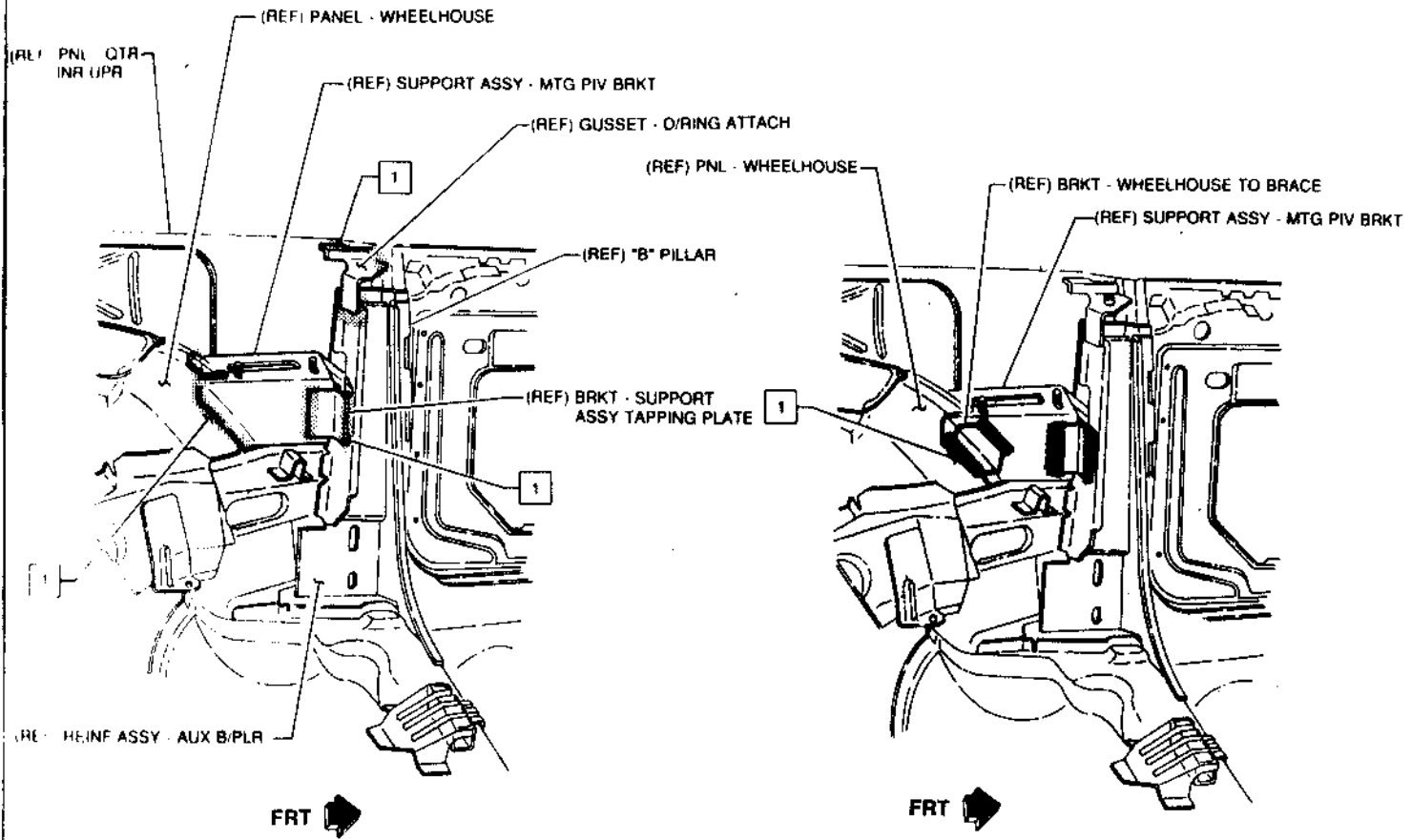

DRAWING RELEASED		DATE	BY	CHK	APP
PCB	LET	1-25-91	MS	CK	APP
		ASC Incorporated Graphix Department Engineering Center Southgate, Michigan 48196		1-25-91 M. B. B. / J. J. M. C. / J. J. / J. J. C. W. B. B.	
1991.5 "F" BODY CONVERTIBLE SEALING - SUPPORT BRACKETS AND GUSSET D/RING ASSEMBLY					
A-27X0-4960-AXXX				SHEET 3D	

Ref	ASC Part No	Description	GM
1	X-00MO-0184-AXXX	SEALER - BRUSH ON	9981111
2	X-00MO-0229-AXXX	TAPE - SEALER	

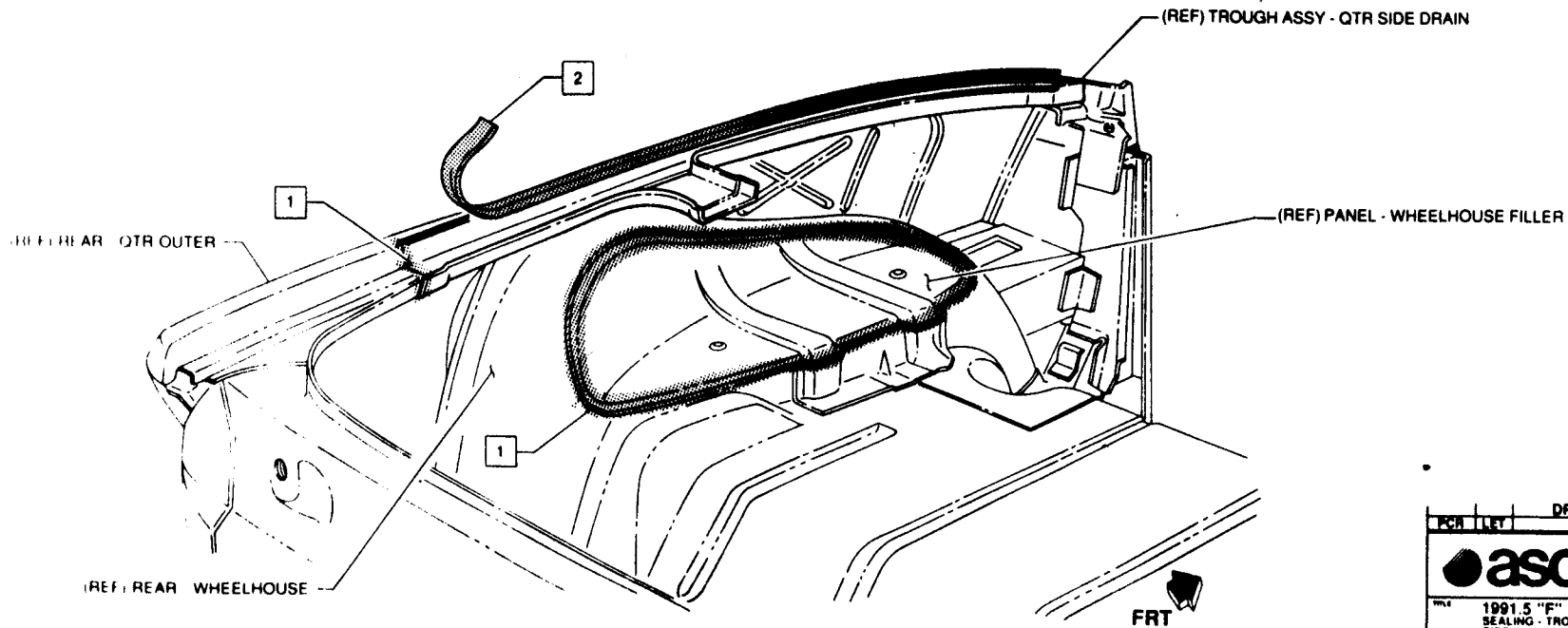
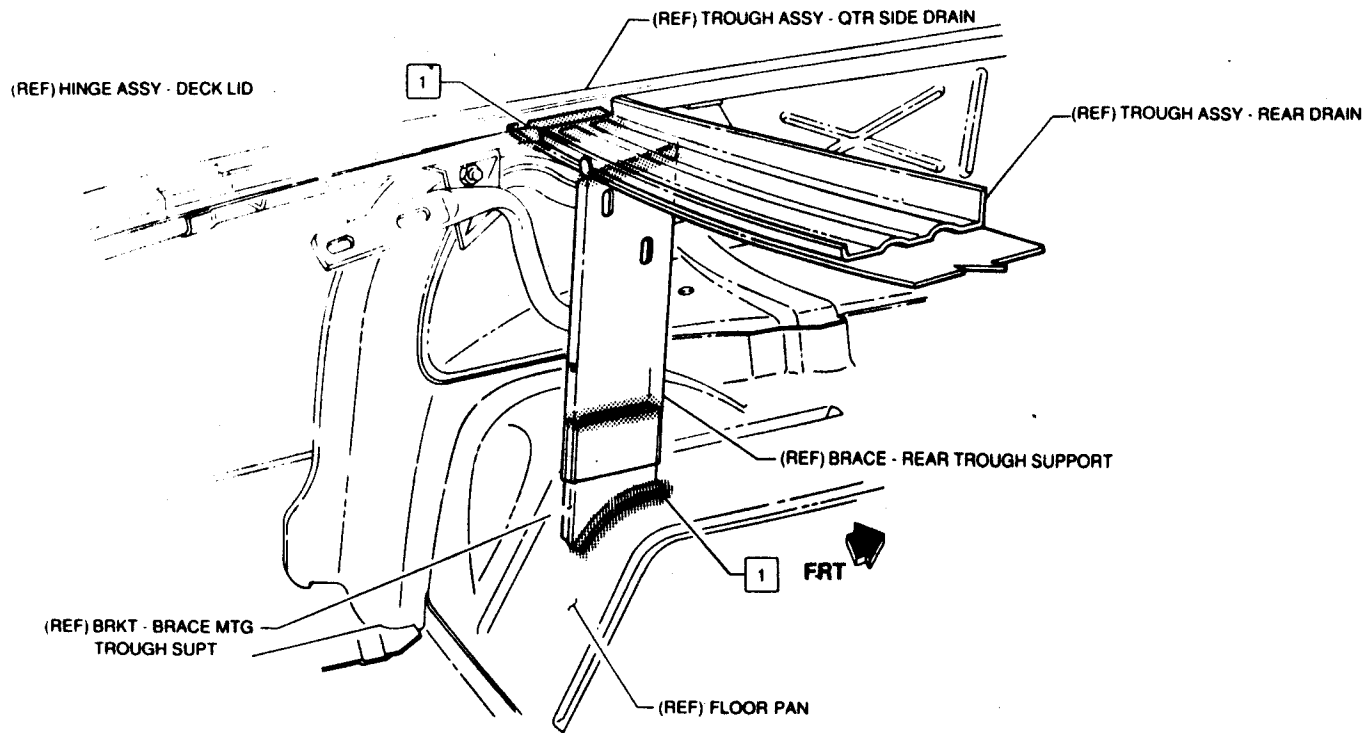

DRAWING RELEASED		DATE	BY
PCN	REV	DATE	BY
			
1991.5 "F" BODY CONVERTIBLE SEALING - TROUGH ASSEMBLY - QUARTER SIDE AND REAR		ASC Incorporated Graphics Department Engineering Center Southgate Michigan 48196	
A-27X0-4960-AXXX		SHEET 3E	