

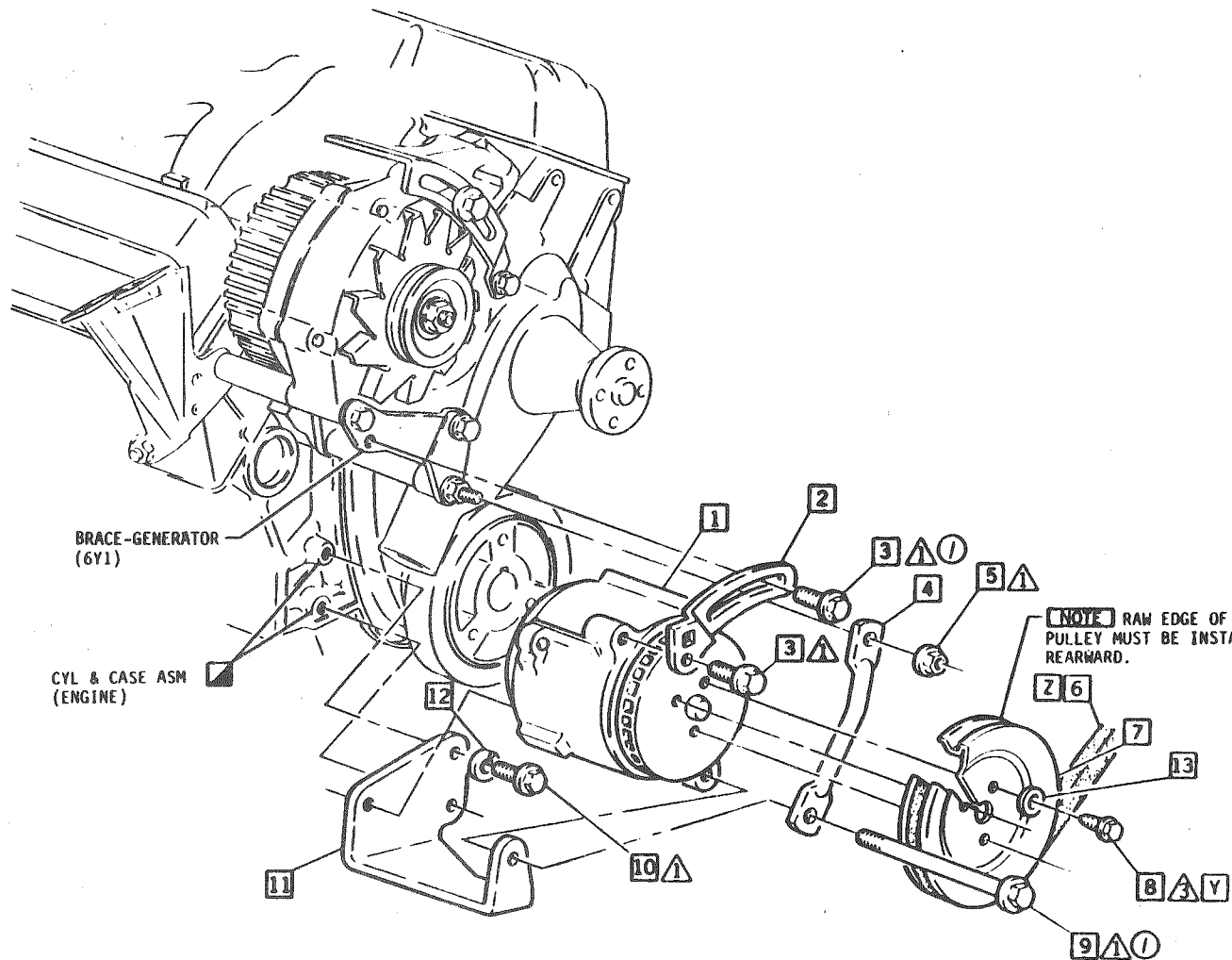

General Motors Corporation
CHEVROLET MOTOR DIVISION

PRODUCT DESCRIPTION MANUAL

ITEM REFERENCE
 PROCESS MATERIAL
 TORQUE
 EXISTING AS PART OF



- 7835396 1 A. I. R. PUMP
- 14037744 2 BRACKET
- 11508251 3 BOLT/SCREW
- 14048884 4 BRACE
- 14057004 5 NUT
- + 458565 6 BELT & LG4 & K79
- + 14037745 6 & LG4 & K64
- 14087007 7 PULLEY
- 14077183 8 BOLT/SCREW
- 11508555 9 BOLT/SCREW
- 9440169 10 BOLT/SCREW
- 14037741 11 SUPPORT
- + 103321 12 WASHER
- 14077184 13 SPACER

NOTE RAW EDGE OF THE PULLEY MUST BE INSTALLED REARWARD.

Y TIGHTEN ALL THREE BOLT/SCREWS 8 TO 12-16 N·m. A SECOND TORQUING OF ALL THREE BOLT/SCREWS TO 15-16 N·m IS REQUIRED USING A CLICK WRENCH, PORT-A-TORQUE, OR OTHER SUITABLE TOOL.

NOTE A MAXIMUM TIME LIMIT OF 10 MINUTES BETWEEN INITIAL AND FINAL TORQUING IS REQUIRED DUE TO ADHESIVE LOCKING MATERIAL ON THE BOLT/SCREW THREADS.

Z FOR BELT ROUTING SEE UPC 6Z.

DYNAMIC (Instal) N·m	HAND (Instal) N·m	DATE	SYB	REVISION	AUTO	DR	CK	ASH	DATE	DIV	TITLE
		10/28/85	1	WAS TORQUE 2 (2 PLACES)					01NO84	CHEVROLET	1986 F PASSENGER 14089402
			2	TORQUE 20-30 REMOVE (FE 1770)	93671	CU	78		DR R KOCH		A. I. R. PUMP FA00 & LB9/LG4 & NA5/NB2
									CR A. McKeown/AM		
									APPR S		
									APPR		
									APPR		
									APPR		
										REF ECA 41600 C/O 220C84	11-26557 (S)
											UPC 6T
											SHEET C2

FULLY DRIVEN, SEATED & NOT STOPPED