

Detroit TrueTrac Gear style LSD

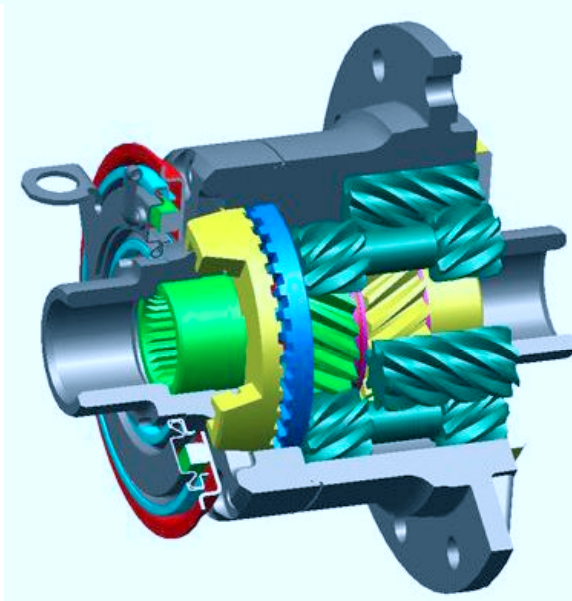

The Detroit TrueTrac LSD is one of the more popular aftermarket differentials available for purchase. Averaging \$500 for the unit, the TrueTrac is a great buy due to the fact that it never wears out. The TrueTrac achieves its ability to limit slip by disengaging the side gear from the pinions when one wheel begins to spin more than it should. This slows down or all together stops the spin while maintaining traction for the other wheel.

TORSEN Gear style LSD

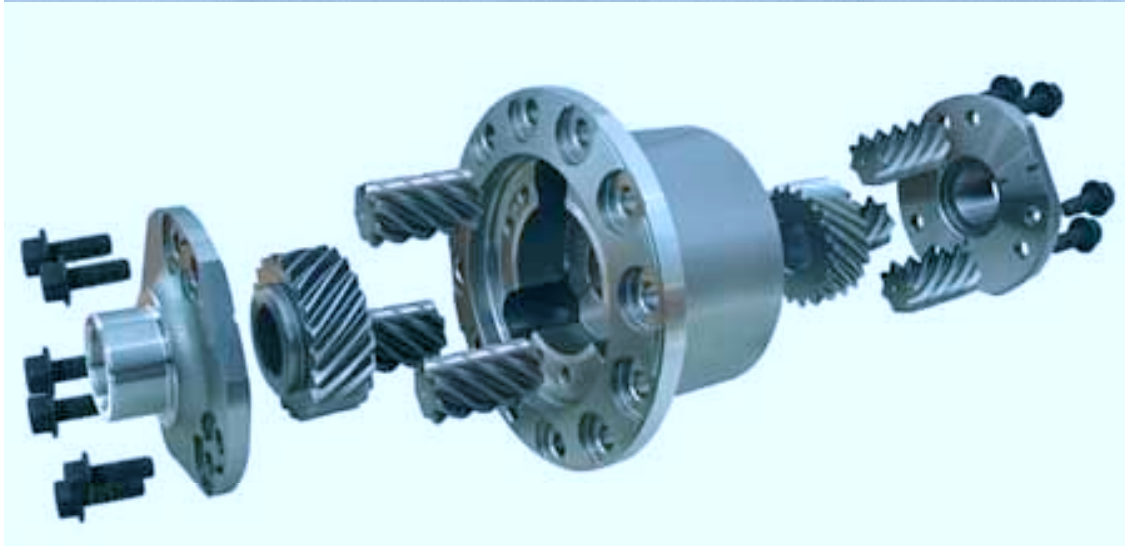
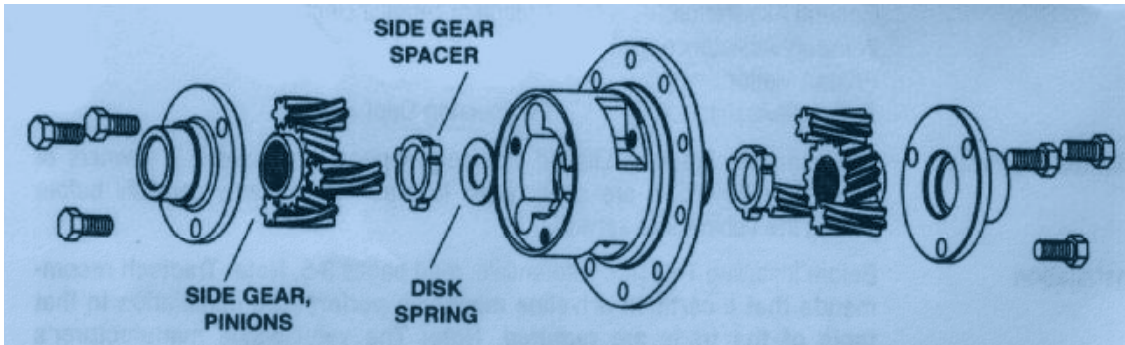
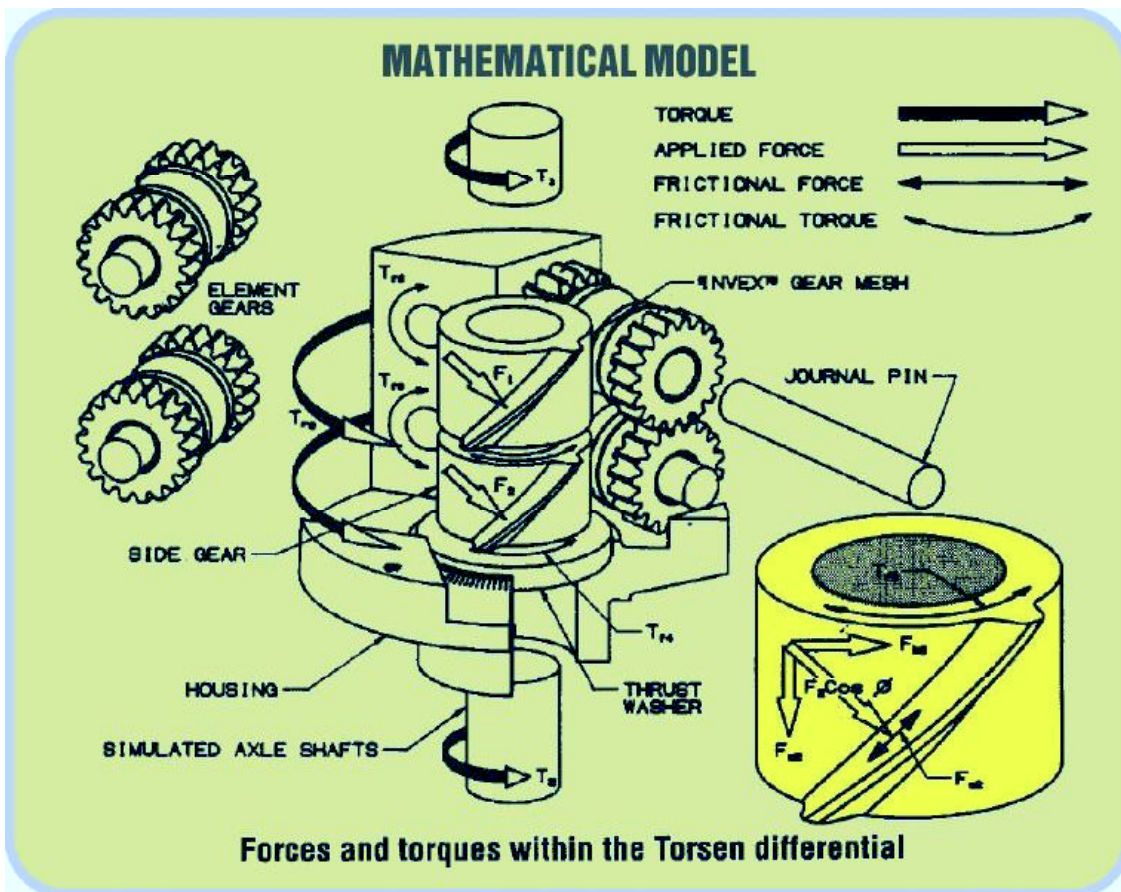

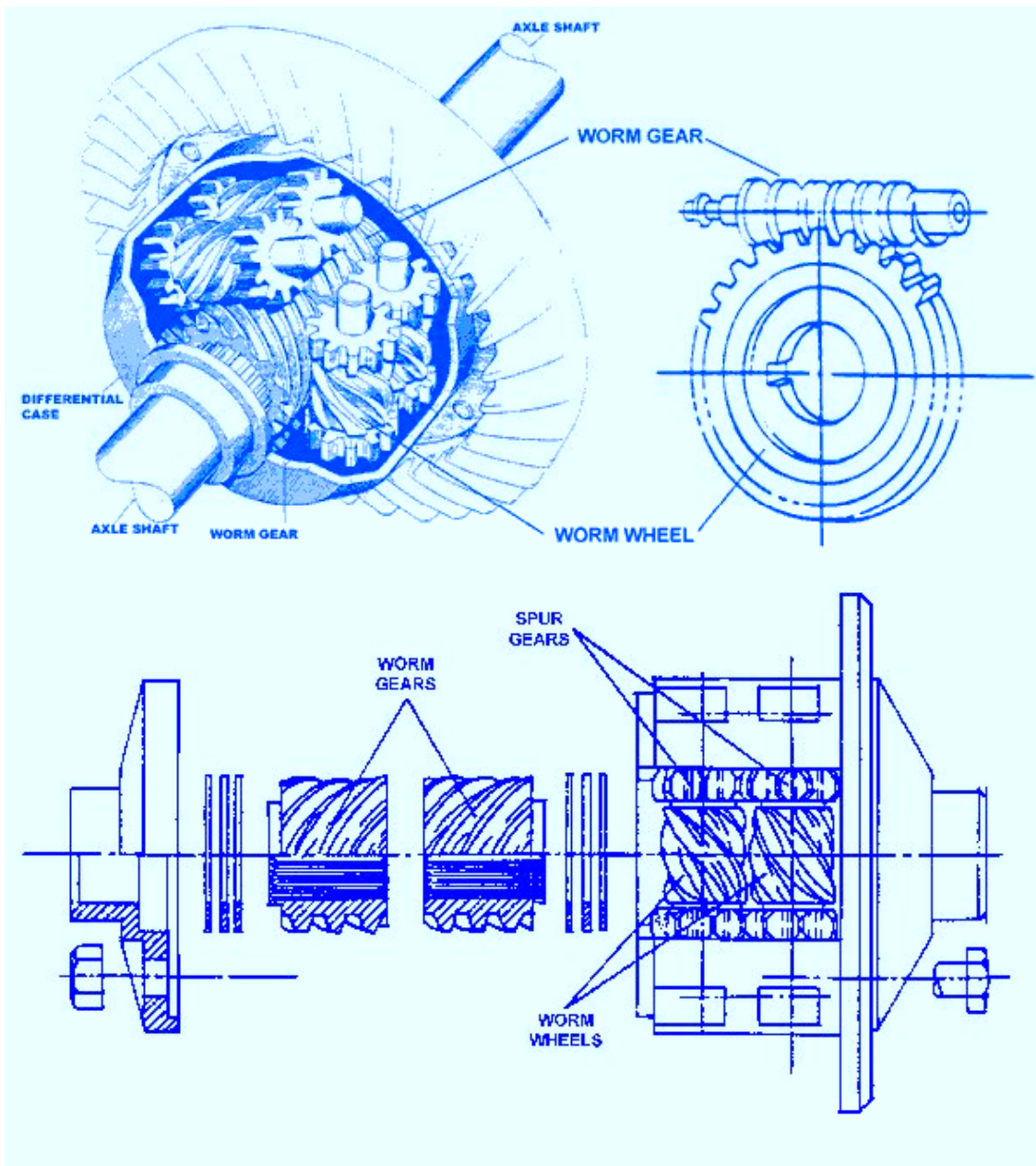

GLEASON-TORSEN DIFFERENTIAL

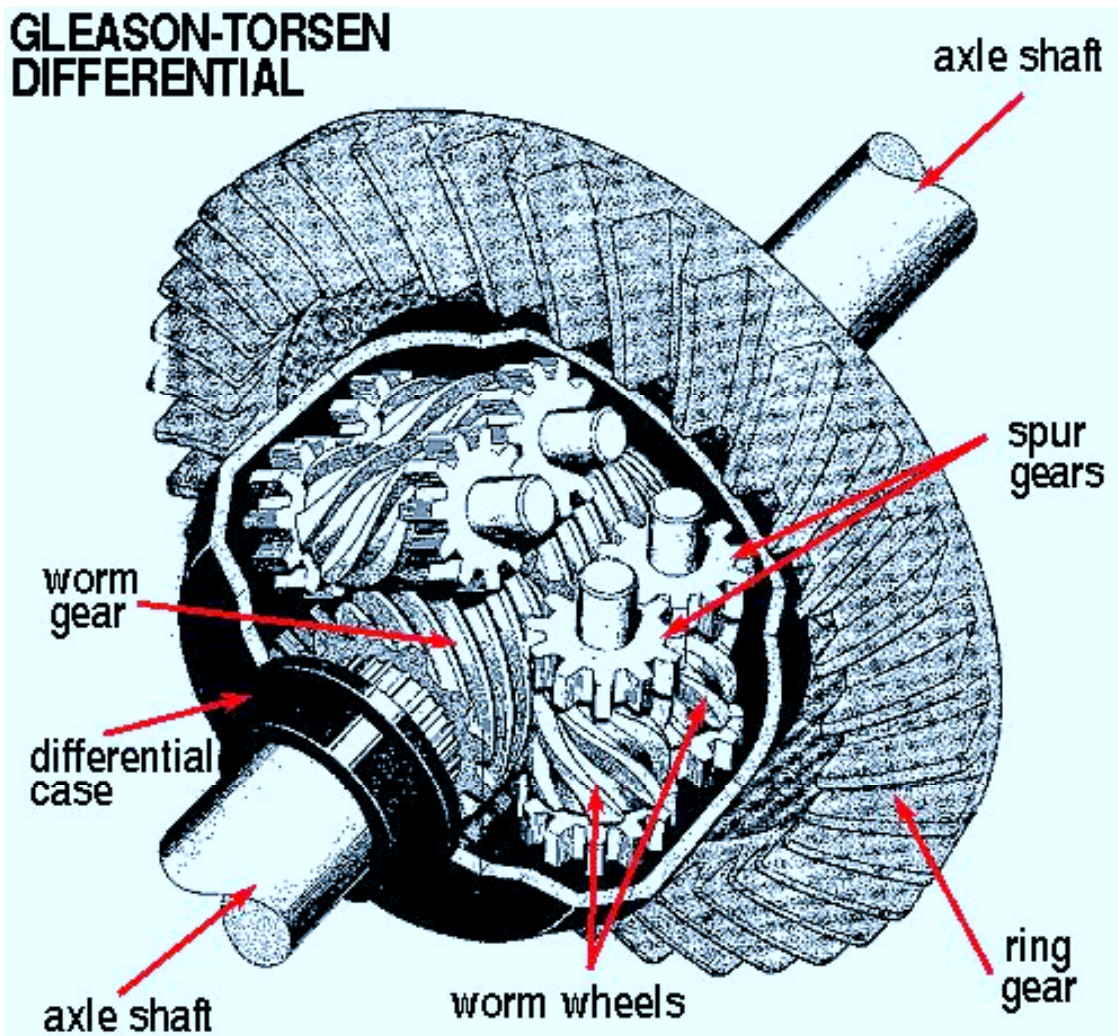

The TORSEN LSD is popular with many college FSAE teams. It operates on the same basic principle as the TrueTrac, but it uses different means to accomplish its limiting of slip. The worm gears of each axle are independent of each other and they each turn a set of worm wheels which are linked to the other axle's worm wheels via a set of spur gears. When the worm gear of one axle begins to turn faster than it should due to loss of traction, it in turn spins its worm wheels faster, but since they are linked to the other axle's worm wheels and worm gears by spur gears, the axle that lost traction slows down or stops the spinning all together.